

Centrifugal Belt-Drive In-Line Duct Blower



Designed for indoor clean air applications including intake, exhaust, return, or make-up air systems in industrial or commercial buildings. Rugged construction allows fan to be installed in ductwork either horizontally or vertically. Duct collars provide easy duct connections. Access panels are included on each side of the unit.

- Aluminum backward inclined, nonoverloading centrifugal wheel design
- UL/cUL 705 Listed for Power Ventilators
- Maximum inlet air temperature: 160° F
- Bearing and motor cover provide longer service life
- Regreaseable pillow block bearings



Dayton Electric Mfg. Co. certifies that the blowers shown herein are licensed to bear the AMCA seal. The ratings shown are based on tests and procedures performed in accordance with AMCA Publication 211 and AMCA Publication 311 and comply with the requirements of the AMCA Certified Ratings Program.

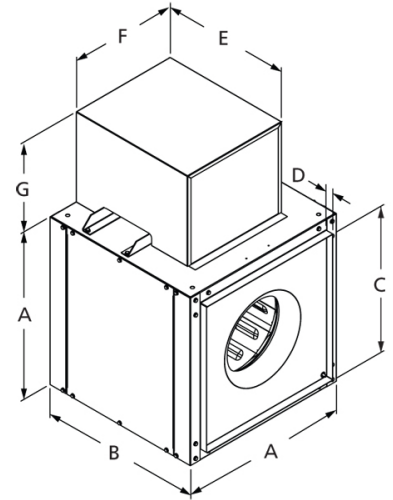

A	B	C	D	E	F
28 in	28 in	23 7/8 in	1 1/2 in	21 in	17 in
G					
13 3/8 in					

Performance Characteristics

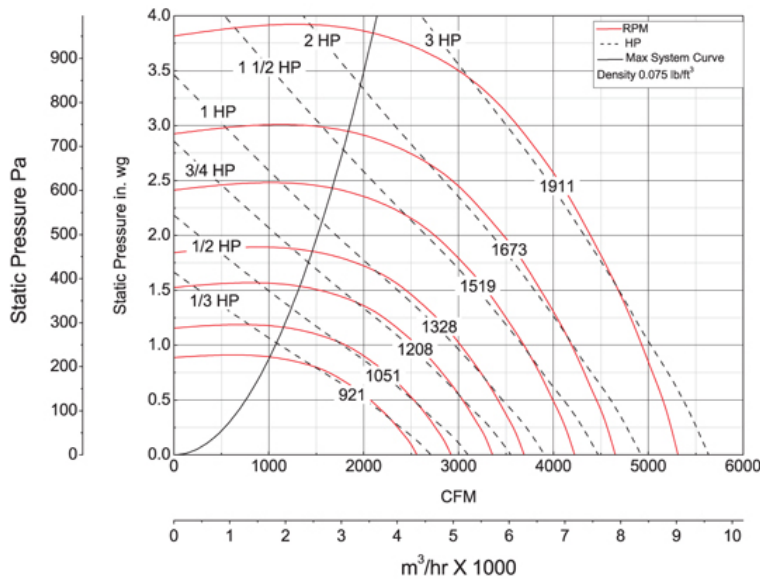

Construction Features

Impeller Diameter (Typ.)	18 in
Impeller Type	Backward Inclined Centrifugal
Impeller Material	Aluminum
Max Inlet Temp	160 °F
Bearing Type	Regreaseable Pillow Block
Drive Package Description	Drives By Others
Warranty Length	1 Year

Air & Sound Performance

Motor HP	Max BHP	Fan RPM	CFM @	0.000" SP	0.125" SP	0.250" SP	0.375" SP	0.500" SP	0.625" SP	0.750" SP	0.875" SP	1.000" SP	1.250" SP	1.500" SP	1.750" SP	2.000" SP	2.250" SP	2.500" SP	2.750" SP	3.000" SP
1/3	0.35	921	CFM	2561	2474	2360	2225	2067	1877	1630	—	—	—	—	—	—	—	—	—	—
			Sones	11.0	10.8	10.5	10.2	9.8	9.3	9.1	—	—	—	—	—	—	—	—	—	—
1/2	0.52	1051	CFM	2922	2852	2755	2648	2527	2390	2236	2042	1799	—	—	—	—	—	—	—	—
			Sones	12.7	12.6	12.3	11.9	11.6	11.2	10.8	10.4	10.0	—	—	—	—	—	—	—	—
3/4	0.79	1208	CFM	3359	3299	3221	3135	3040	2938	2822	2697	2559	2205	—	—	—	—	—	—	—
			Sones	15.0	14.9	14.7	14.4	14.1	13.8	13.4	12.9	12.4	11.6	—	—	—	—	—	—	—
1	1.05	1328	CFM	3692	3638	3573	3497	3416	3327	3234	3129	3018	2765	2438	—	—	—	—	—	—
			Sones	17.1	17.1	16.9	16.6	16.2	15.9	15.6	15.2	14.7	13.9	13.0	—	—	—	—	—	—
1 1/2	1.57	1519	CFM	4223	4176	4127	4061	3994	3924	3848	3770	3685	3499	3296	3045	2744	2056	—	—	—
			Sones	22.0	21.0	21.0	21.0	20.0	20.0	19.6	19.3	19.1	18.1	17.3	16.5	15.6	13.7	—	—	—
2	2.10	1673	CFM	4651	4608	4565	4511	4452	4390	4326	4258	4187	4034	3866	3682	3468	3215	2919	2025	—
			Sones	26.0	25.0	25.0	25.0	25.0	24.0	24.0	23.0	23.0	22.0	22.0	21.0	20.0	19.1	18.2	15.5	—
3	3.13	1911	CFM	5313	5275	5237	5200	5149	5096	5044	4988	4931	4810	4685	4538	4388	4227	4050	3848	3610
			Sones	36.0	35.0	35.0	34.0	33.0	33.0	32.0	31.0	31.0	30.0	30.0	29.0	29.0	28.0	27.0	27.0	26.0

Performance certified is for installation type B: Free inlet, Ducted outlet. Power rating (BHP) does not include transmission losses. Performance ratings do not include the effects of appurtenances (accessories). The sound ratings shown are loudness values in fan sones at 5 ft. (1.5 m) in a hemispherical free field calculated per AMCA Standard 301. Values shown are for installation type B: Free inlet hemispherical fan sone levels.