

## Wall Mount Cabinet Exhaust Fan



Designed for commercial and industrial applications requiring assembled packaged units able to deliver high volumes of air at low static pressures. Fans are completely assembled and ready for installation. Construction includes galvanized steel fan panel, fabricated propeller and bolted cabinets. Fan includes wall mounting angles for easy installation.

- Air handling quality bearings meet minimum of L10-100,000 hours
- Maximum inlet air temperature: 104° F
- Variable pitch adjustable motor pulley to optimize fan performance
- Exhaust damper blade is top-pivoting gravity return

AMCA Sound & Air Dayton Electric Mfg. Co. certifies that the ventilators shown herein are licensed to bear the AMCA seal. The ratings shown are based on tests and procedures performed in accordance with AMCA Publication 211 and AMCA Publication 311 and comply with the requirements of the AMCA Certified Ratings Program.

UL/cUL 705



CSA Certified Motor

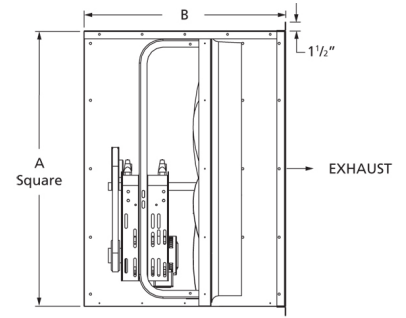

A	B
28 1/4 in	34 1/8 in

## Performance Characteristics

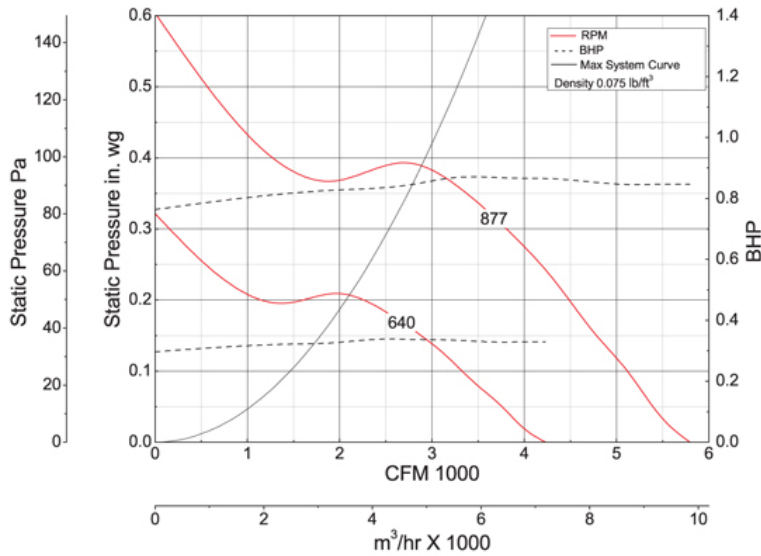

## Construction Features

Impeller Diameter (Typ.)	24 in
Impeller Type	Propeller
Impeller Material	Fabricated Steel
Max Inlet Temp	104 °F
Bearing Type	Regreaseable Cast Pillow Block
Drive Package Description	Drives Assembled
Warranty Length	1 Year

## Motor Information

Motor Item Number	50M239
Voltage	208-230/460
Hertz (Cycle)	60 Hz
Motor Phase	3
Motor Enclosure	Totally Enclosed Air-Over
RPM	1,725 rpm
Full Load Amps	2.8-2.7/1.4

## Other Components

Component	Description	Item #
Fan Description	Exhaust Fan	—
Driver Sheave	1VL40x5/8	3X264
Driven Sheave	BK80H	3X597
Driven Bushing	H x 3/4	3X573

## Air & Sound Performance

Motor HP	Max BHP	Fan RPM	CFM @	0.000" SP	0.125" SP	0.250" SP	0.375" SP
3/4	0.86	877	CFM	5796	4950	4165	3020
			Sones	21.0	16.0	14.9	15.3

Performance certified is for installation type A: Free inlet, Free outlet. Power rating (BHP) does not include transmission losses. Performance ratings include the effects of a birdscreen and damper in the air stream. Speed (RPM) shown is nominal. Performance is based on actual speed of test. The sound ratings shown are loudness values in fan sones at 5 ft. (1.5 m) in a hemispherical free field calculated per AMCA Standard 301. Values are for installation type A: Free inlet hemispherical sone levels.

Catalog 405, January 2010

## Operating Range of Drive Package

Turns Open	FRPM @ 0 TO	FRPM @ 1/2 TO	FRPM @ 1 TO	FRPM @ 1 1/2 TO	FRPM @ 2 TO	FRPM @ 2 1/2 TO	FRPM @ 3 TO	FRPM @ 3 1/2 TO	FRPM @ 4 TO	FRPM @ 4 1/2 TO	FRPM @ 5 TO
Approx. FRPM	877	859	834	810	786	761	737	713	688	664	640