

Assembled Centrifugal Belt-Drive Downblast Exhaust Ventilator



Designed to meet the general clean air exhaust requirements for industrial and commercial buildings. Features a fully rolled windband bead for increased stability and easy transport. Fresh outside air is drawn in under the motor cover to maximize motor life.

- Aluminum backward inclined, nonoverloading centrifugal wheel design
- Maximum inlet air temperature: 180° F
- NEMA 1 junction box located in motor enclosure
- Optional NEMA 1 and 4 disconnects available
- Sealed pillow block bearings
- UL/cUL 705 Listed for Power Ventilators
- Air handling quality bearings meet minimum of L10-100,000 hours

AMCA Sound & Air Dayton Electric Mfg. Co. certifies that the ventilators shown herein are licensed to bear the AMCA seal. The ratings shown are based on tests and procedures performed in accordance with AMCA Publication 211 and AMCA Publication 311 and comply with the requirements of the AMCA Certified Ratings Program.

UL/cUL 705



CSA Certified Motor

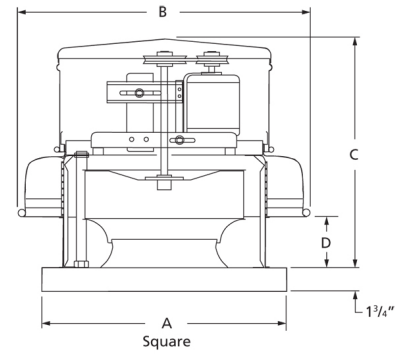

A	B	C	D
26 in	28 3/8 in	25 3/8 in	4 in

Performance Characteristics

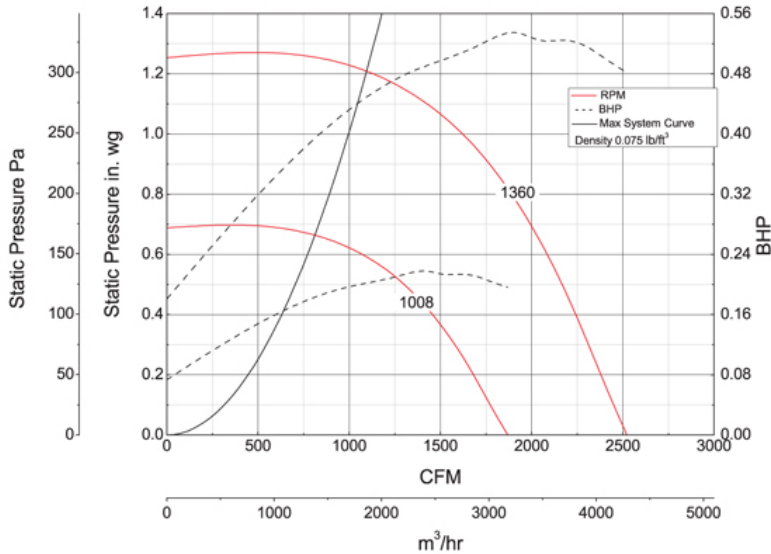

Construction Features

Impeller Diameter (Typ.)	14 3/4 in
Impeller Type	Backward Inclined Centrifugal
Impeller Material	Aluminum
Max Inlet Temp	180 °F
Bearing Type	Sealed Pillow Block
Drive Package Description	Drives Assembled
Warranty Length	1 Year

Motor Information

Motor Item Number	1AGG3
Voltage	115/208-230
Hertz (Cycle)	60 Hz
Motor Phase	1
Motor Enclosure	Open Drip Proof
RPM	1,725 rpm
Full Load Amps	7.2/3.6-3.6

Other Components

Component	Description	Item #
Fan Description	Exhaust Fan	—
Belt	4L25 (QTY: 1)	4L250
Driver Sheave	1VL40x5/8	3X264
Driven Sheave	AK51x3/4	3X786

Air & Sound Performance

Motor HP	Max BHP	Fan RPM	CFM @	0.000" SP	0.125" SP	0.250" SP	0.375" SP	0.500" SP	0.625" SP	0.750" SP	0.875" SP	1.000" SP
1/2	0.53	1360	CFM	2523	2433	2347	2259	2166	2062	1943	1793	1602
			Sones	14.6	14.3	13.9	13.5	13.1	12.7	12.2	11.6	11.0

Performance certified is for installation type A: Free inlet, Free outlet. Power rating (BHP) does not include transmission losses. Performance ratings include the effects of a birdscreen in the airstream. The sound ratings shown are loudness values in fan sones at 5 ft. (1.5 m) in a hemispherical free field calculated per AMCA Standard 301. Values shown are for installation type A: Free inlet hemispherical sone levels.

Catalog 405, January 2010

Operating Range of Drive Package

Turns Open	FRPM @ 0 TO	FRPM @ 1/2 TO	FRPM @ 1 TO	FRPM @ 1 1/2 TO	FRPM @ 2 TO	FRPM @ 2 1/2 TO	FRPM @ 3 TO	FRPM @ 3 1/2 TO	FRPM @ 4 TO	FRPM @ 4 1/2 TO	FRPM @ 5 TO
Approx. FRPM	1338	1302	1265	1228	1192	1155	1118	1082	1045	1008	—