

## Insulated Ventilator

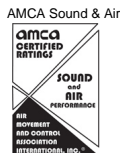

Insulated, quiet, high performance exhaust ventilators designed for residential, commercial, institutional and industrial applications. Factory assembled for horizontal discharge. Constructed of galvanized steel and a molded white polystyrene, easy-to-clean grille. Hardware and mounting brackets are included.

- Acoustic insulation absorbs sound for quiet operation
- Spring loaded aluminum backdraft damper eliminates rattling
- External electrical access reduces installation time



Dayton Electric Mfg. Co. certifies that the ventilators shown herein are licensed to bear the AMCA seal. The ratings shown are based on tests and procedures performed in accordance with AMCA Publication 211 and AMCA Publication 311 and comply with the requirements of the AMCA Certified Ratings Program.

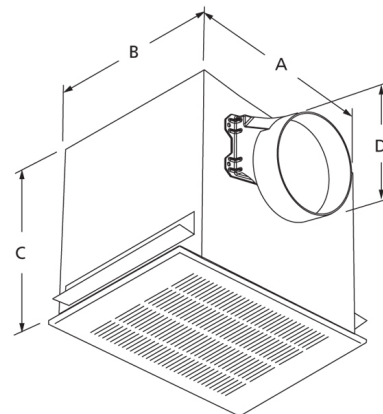

A	B	C	D
13 1/4 in	10 5/8 in	9 in	6 in

## Performance Characteristics

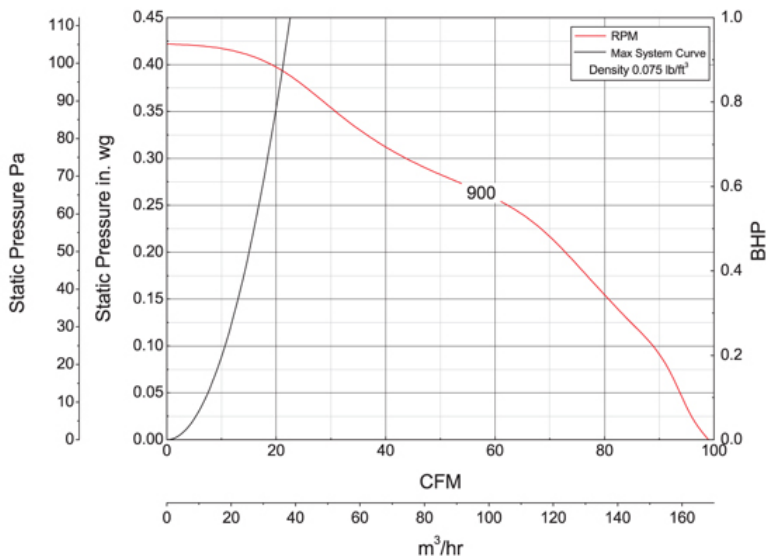

## Construction Features

<b>Impeller Type</b>	Forward Curved Centrifugal
<b>Impeller Material</b>	Polypropylene
<b>Max Inlet Temp</b>	104 °F
<b>Warranty Length</b>	1 Year

## Motor Information

<b>Motor Item Number</b>	21DY26
<b>Voltage</b>	115
<b>Hertz (Cycle)</b>	60 Hz
<b>Motor Phase</b>	1
<b>Motor Enclosure</b>	Open Drip Proof
<b>RPM</b>	900 rpm
<b>Full Load Amps</b>	0.34

## Air & Sound Performance

Motor HP	Max BHP	Fan RPM	CFM @	0.000" SP	0.125" SP	0.250" SP
—	—	900	CFM	110	91	67
			Sones	0.4	0.5	1.1

Performance certified is for installation type B: Free inlet, Ducted outlet. Performance ratings include the effects of an inlet grille and backdraft damper. Speed (RPM) shown is nominal. Performance is based on actual speed of test. The sound ratings shown are loudness values in fan sones at 5 ft. (1.5 m) in a spherical free field calculated per AMCA Standard 301. Values shown are for installation type B: Free inlet spherical sone levels.