

Variable Speed Electronically Commutated (EC) Ventilator



Designed for use in restaurants, schools, commercial, and industrial applications to exhaust contaminated air from kitchen range hoods, up and away from the roof. Leakproof, spun aluminum construction features a fully rolled windband for increased stability. Energy Saving units feature EC motors which allow up to 80% usable turndown. Motor features potentiometer dial for speed adjustment. Optional Variable-Speed Control Kit (43Y140) can be used to remotely control speed.

- Aluminum backward inclined, nonoverloading centrifugal wheel design
- NEMA 1 junction box located in motor enclosure
- Optional NEMA 1 and 4 disconnects available
- Maximum inlet air temperature: 300° F
- High-efficiency brushless DC motor
- UL/cUL 705 Listed for Power Ventilators
- UL/cUL 762 Listed for Restaurant Exhaust Appliances



GREEN Product

- Variable Speed capable of 80% turn down at a minimum of 85% efficiency at all speeds
- Reduce Energy Consumption

AMCA Sound & Air



Dayton Electric Mfg. Co. certifies that the ventilators shown herein are licensed to bear the AMCA seal. The ratings shown are based on tests and procedures performed in accordance with AMCA Publication 211 and AMCA Publication 311 and comply with the requirements of the AMCA Certified Ratings Program.

UL/cUL 762

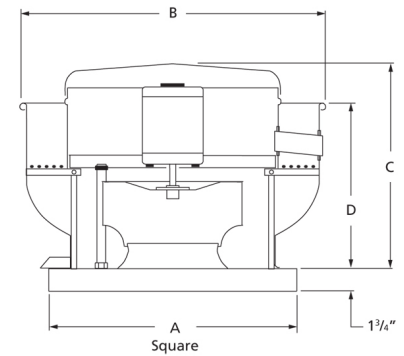

A	B	C	D
19 in	24 7/8 in	28 1/4 in	17 3/8 in

Performance Characteristics

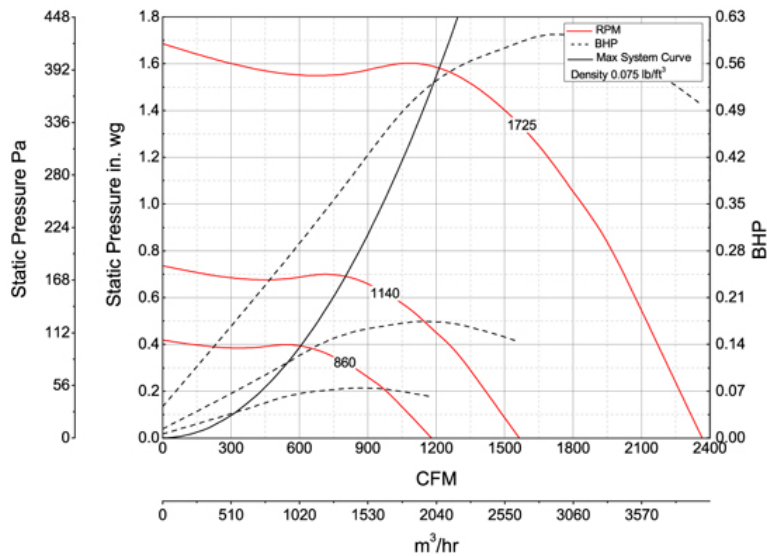

Construction Features

Impeller Diameter (Typ.)	13 1/4 in
Impeller Type	Backward Inclined Centrifugal
Impeller Material	Aluminum
Max Inlet Temp	300 °F
Warranty Length	1 Year

Motor Information

Motor Item Number	43Y138
Voltage	115
Hertz (Cycle)	60 Hz
Motor Phase	1
Motor Enclosure	Open
RPM	rpm
Full Load Amps	10.6

Air & Sound Performance

Motor HP	Max BHP	Fan RPM	CFM @	0.000" SP	0.125" SP	0.250" SP	0.375" SP	0.500" SP	0.625" SP	0.750" SP	0.875" SP	1.000" SP	1.250" SP	1.500" SP
3/4	0.07	860	CFM	1180	1057	914	675	—	—	—	—	—	—	—
			Sones	8.5	8.3	7.7	6.9	—	—	—	—	—	—	—
3/4	0.17	1140	CFM	1564	1471	1379	1280	1144	964	—	—	—	—	—
			Sones	12.5	12.2	11.8	11.2	10.3	9.7	—	—	—	—	—
3/4	0.60	1725	CFM	2366	2305	2244	2183	2122	2061	1994	1926	1838	1646	1365
			Sones	18.8	18.6	18.4	18.2	18.0	17.6	17.2	16.8	16.4	15.3	14.1

Performance certified is for installation type A: Free inlet, Free outlet. Performance ratings do not include the effects of appurtenances (accessories). The sound ratings shown are loudness values in fan sones at 5 ft. (1.5 m) in a hemispherical free field calculated per AMCA Standard 301. Values shown are for installation type A: Free inlet hemispherical sone levels.