

Centrifugal Direct-Drive Upblast Exhaust Ventilator



Designed for use in restaurants, schools, commercial, and industrial applications to exhaust contaminated air from kitchen range hoods, up and away from the roof. Leakproof, spun aluminum construction features a fully rolled windband for increased stability.

- Aluminum backward inclined, nonoverloading centrifugal wheel design
- NEMA 1 junction box located in motor enclosure
- Optional NEMA 1 and 4 disconnects available
- Maximum inlet air temperature: 300° F
- UL/cUL 705 Listed for Power Ventilators
- UL/cUL 762 Listed for Restaurant Exhaust Appliances



Dayton Electric Mfg. Co. certifies that the ventilators shown herein are licensed to bear the AMCA seal. The ratings shown are based on tests and procedures performed in accordance with AMCA Publication 211 and AMCA Publication 311 and comply with the requirements of the AMCA Certified Ratings Program.

UL/cUL 762



E53236
MH12596

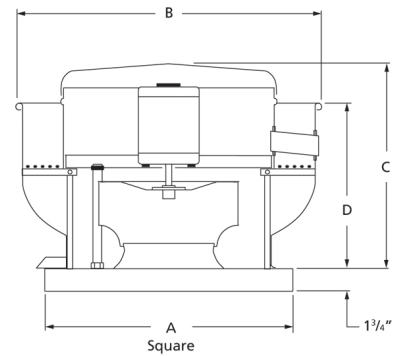

A	B	C	D
19 in	24 7/8 in	22 in	17 3/8 in

Performance Characteristics

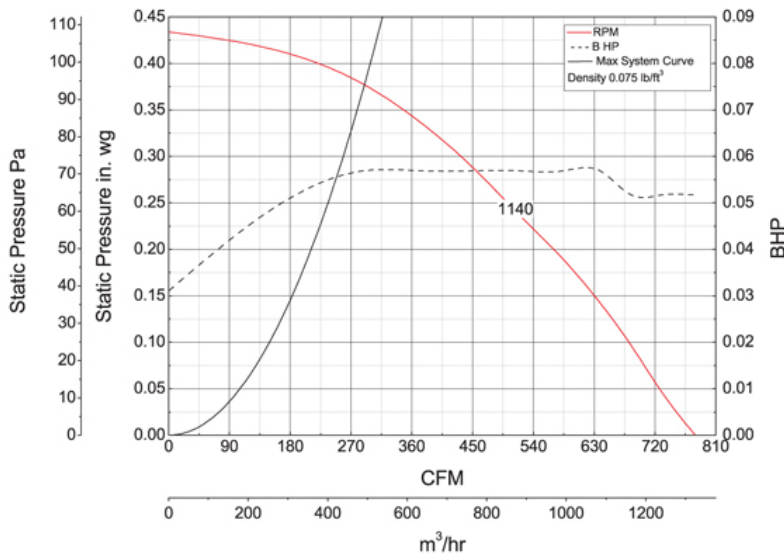

Construction Features

Impeller Diameter (Typ.)	11 in
Impeller Type	Backward Inclined Centrifugal
Impeller Material	Aluminum
Max Inlet Temp	300 °F
Warranty Length	1 Year

Motor Information

Motor Item Number	4YU23
Voltage	115
Hertz (Cycle)	60 Hz
Motor Phase	1
Motor Enclosure	Open Air-Over
RPM	1,140 rpm
Full Load Amps	2.2

Air & Sound Performance

Motor HP	Max BHP	Fan RPM	CFM @	0.000" SP	0.125" SP	0.250" SP	0.375" SP
1/6	0.06	1140	CFM	780	656	502	294
			Sones	9.1	8.7	8.3	7.9

Performance certified is for installation type A: Free inlet, Free outlet. Performance ratings do not include the effects of appurtenances (accessories). The sound ratings shown are loudness values in fan sones at 5 ft. (1.5 m) in a hemispherical free field calculated per AMCA Standard 301. Values shown are for installation type A: Free inlet hemispherical sone levels.